

PFK (立式)單軸型自配馬達減速機

PFK Self-Contained Motor Type Gear Reducer

PFK 18 - 0200 - 10

減速比 Ratio: 1/10

馬力 HP: 200W

出力軸尺寸 Output Shaft Dimension: $\phi 18$

PFK立式單軸型 Vertical Type (Single-Shaft)

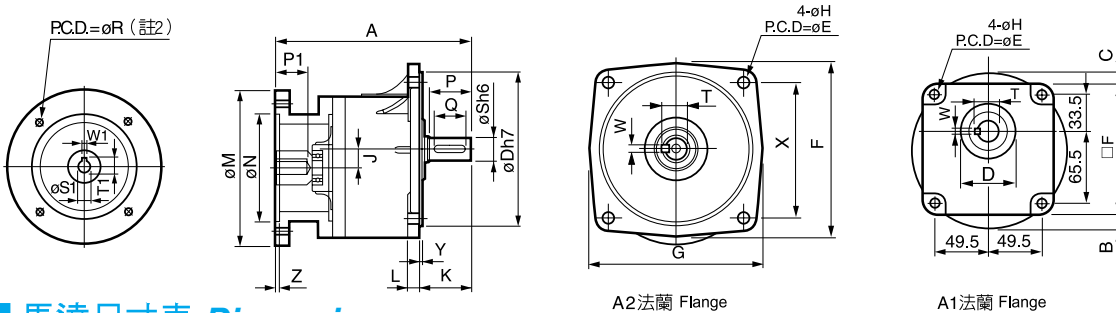

軸徑40mm 之鍵寬(W):
台灣尺寸: 10mm
大陸尺寸: 12mm

馬達尺寸表 Dimensions

馬力 HP	減速比 Gear Ratio	框號 Type	A	B	C	D	E	X	F	G	H	J	K	L	M	N	R	Y	Z	輸入軸端 Input Shaft				輸出軸端 Output shaft					重量 App.Wt. Kg	備註
																				P1	S1	T1	W1	P	Q	S	T	W		
0.1KW	5~50	18	159	20	20	50	140	99	122	-	9	15.98	40	12	160	110	130	5	4	26	11	12.7	4	30	22	18	20	5	5	A1法蘭
	60~200	22	191	7	-	148	185	131	176	168	11	17.66	50	12	160	110	130	3.5	4	26	11	12.7	4	40	30	22	25	7	6.2	A2法蘭
0.2KW	5~10	18	159	20	20	50	140	99	122	-	9	15.98	40	12	160	110	130	5	4	26	11	12.7	4	30	22	18	20	5	5	A1法蘭
	12.5~25	18	159	20	20	50	140	99	122	-	9	15.98	40	12	160	110	130	5	4	26	11	12.7	4	30	22	18	20	5	5	A1法蘭
	12.5~100	22	191	7	-	148	185	131	176	168	11	17.66	50	22	160	110	130	3.5	4	26	11	12.7	4	40	30	22	25	7	6.2	A2法蘭
	120~200	28	220	-	-	170	220	156	205	195	ϕ_{14L}^{011}	23.11	60	13	160	110	130	4	4	26	11	12.7	4	45	35	28	31	7	7.5	A2法蘭
0.4KW	5~10	22	191	7	-	148	185	131	176	168	11	17.66	50	12	160	110	130	3.5	4	33	14	16.2	5	40	30	22	25	7	6.2	A2法蘭
	12.5~25	22	191	7	-	148	185	131	176	168	11	17.66	50	12	160	110	130	3.5	4	33	14	16.2	5	40	30	22	25	7	6.2	A2法蘭
	12.5~100	28	220	-	-	170	220	156	205	195	ϕ_{14L}^{011}	23.11	60	13	160	110	130	4	4	33	14	16.2	5	45	35	28	31	7	7.5	A2法蘭
	120~200	32	250	-	-	185	255	180	241	225	15	30.22	70	15	160	110	130	4	4	33	14	16.2	5	55	45	32	36.5	10	19	A2法蘭
0.75KW	5~25	28	254	17.5	-	170	220	156	205	195	ϕ_{14L}^{011}	23.11	60	13	200	130	165	4	4.5	43	19	21.7	6	45	35	28	31	7	7.5	A2法蘭
	30~100	32	284	2	-	185	255	180	241	225	15	30.22	70	15	200	130	165	4	4.5	43	19	21.7	6	55	45	32	36.5	10	20.5	A2法蘭
1.5KW	120~200	40	340	-	-	230	310	219	297	268	15	37.96	76	20	200	130	165	5	4.5	43	19	21.7	6	65	55	40	44	$\frac{10}{12}$	39	A2法蘭
	5~30	32	303	2	-	185	255	180	241	225	15	30.22	70	15	200	130	165	4	4.5	53	24	27.2	8	55	45	32	36.5	10	20.5	A2法蘭
	40~100	40	341	-	-	230	310	219	297	268	15	37.96	76	20	200	130	165	5	4.5	53	24	27.2	8	65	55	40	44	$\frac{10}{12}$	39	A2法蘭
2.2KW	120~200	50	351	13.5	-	250	352	249	320	290	18	39.2	86	22	200	130	165	5	4.5	53	24	27.2	8	75	65	50	53.5	14	52.2	A2法蘭
	5~10	32	317	27	-	185	255	180	241	225	15	30.22	70	15	250	180	215	4	4.5	63	28	31.2	8	55	45	32	36.5	10	21.5	A2法蘭
	15~60	40	373	2.5	-	230	310	219	297	268	15	37.96	76	20	250	180	215	5	4.5	63	28	31.2	8	65	55	40	44	$\frac{10}{12}$	40	A2法蘭
3.7KW	75~120	50	383	13.5	-	250	352	249	320	290	18	39.2	86	22	250	180	215	5	4.5	63	28	31.2	8	75	65	50	53.5	14	54	A2法蘭
	5~20	40	373	2.5	-	230	310	219	297	268	15	37.96	76	20	250	180	215	5	4.5	63	28	31.2	8	65	55	40	44	$\frac{10}{12}$	40	A2法蘭
25~100	50	383	13.5	-	250	352	249	320	290	18	39.2	86	22	250	180	215	5	4.5	63	28	31.2	8	75	65	50	53.5	14	54	A2法蘭	

- 淺藍色為輕扭力之機型
- 中間螺絲孔 1/8~1/4 HP 為 M8*P1.25.
1/2~2 HP 為 M10*P1.5.
3 HP 為 M14*P2.
- 軸徑40mm之鍵寬(w)標準為10mm, 12mm為選用規格。

- Colour in Light blue indicates motor of smaller torque.
- Central screw hole for 1/8 ~ 1/4 HP motor shall be M8*P1.25.
Central screw hole for the 1/2 ~ 2HP motor shall be M10*P1.5.
Central screw hole for the 3HP motor shall be M14*P2.
- Keyway (w) for type 40 is 10mm, 12mm is optional.

以上數值若有變動, 恕不另行通知 We reserve the right to change without further notice.